

— CROSS SECTION —

BEAD DETAIL

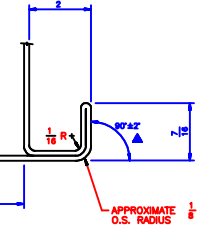

LIP DETAIL

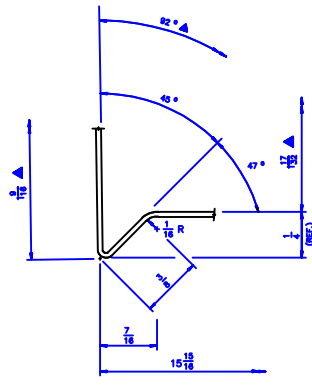
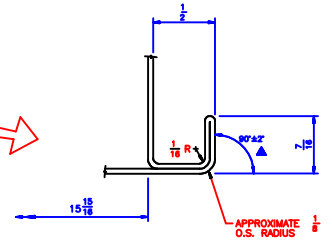

OFFSET DETAIL

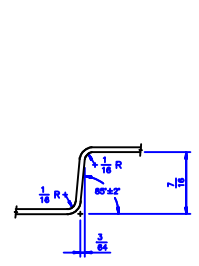

DETAIL - 1
(FLUTE / 3 TYPICAL)

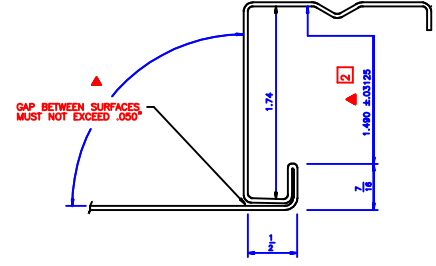

ACCEPTABLE PANEL JOINT TOLERANCE

NOTES:

1. SYMBOL ▲ REPRESENTS CRITICAL DIMENSION OR ANGLE.
2. ANGLE TOLERANCE ±2° AND HORIZONTAL PLANES ±2° FROM HORIZONTAL, EXCEPT AS SHOWN. ALL ANGLES 90°, EXCEPT AS NOTED, SEE DWG. D-038469 FOR STYLWALL II QUALITY CONFORMANCE INFORMATION.
3. CROSS SECTION TOLERANCES SHOWN TO BE HELD THROUGHOUT LENGTH OF PANEL EXCEPT WHERE PANEL IS DISTORTED BY SHEARING OR BENDING. MAXIMUM ALLOWABLE LATERAL OR VERTICAL DISTORTION BY THE SHEARING OPERATIONS IS ±1/32 FROM "AS ROLLED" SHAPE. FORMED TOLERANCES ARE ±1/32, UNLESS NOTED.
4. ALL INSIDE FORMING RADII TO BE 1/16, UNLESS NOTED.
5. ANY REDUCTION IN AREA AT BEND RADII SHALL NOT EXCEED 10% OF ADJACENT MATERIAL THICKNESS.
6. PREPAINTEDED STUCCO EMBOSSED MATERIAL. DEPTH OF EMBOSSEING = .007" TO .011".

PANEL MATERIAL FLAT WIDTH SPECIFICATIONS				
GAGE	NOMINAL THICKNESS	MINIMUM THICKNESS OF MATERIAL	FLAT WIDTH	MAXIMUM EMBOSSED THICKNESS
24	.0276	.0236	24 7/8	.037

B.M.C. MATERIAL SPEC. NO. 10090—GRADE 42

NO.	REVISION	ENGR. NO.	CHECKED ENGR.	DATE	NO.	REVISION	ENGR. NO.	CHECKED ENGR.	DATE	ITEM NO.	REV'D.	PART NUMBER	NAME AND SIZE	MAT'L OR SPEC.
1	GENERAL METHOD CHANGED TO STAMPING	RHE	LED	07/28/84						1				
2	CHANGED PER SPEC. REQUEST.	ACU	JE	05/29/85						2				
3	ADD 1/2" DIA. RADIUS TO CHYED DETAIL PER PLANT REQUEST.	WAS	WJ	11/11/81						3				
		WBL	WBL	11/16/80						4				

TOLERANCES AS FOLLOWS UNLESS OTHERWISE NOTED:				
A. MACHINING	±.015			
B. SHEET METAL SHEARING	THRU TO GA. ±.010			
C. STRUCTURAL LENGTH	±.1"			
D. BRAKE PARTS	±.2"			
E. FINISHING LOCATION	±.1"			
F. ALL WELDING SYMBOLS ARE ACCORDING TO BUTLER STDL. SEE BUTLER STANDARDS BOOK				

DRAWN BY	CHECKED BY	PRODUCT ENGR. APPR.	REV NUMBER	NEXT ASS'N. DWG. NO.	PART GROUP NO.
RHE	LED	D.L. BROYLES	8560	NON-SHIPABLE	010-84
PART WT.	ORDER NUMBER	BUTLER MANUFACTURING COMPANY	GENERAL OFFICES - KANSAS CITY, MISSOURI	FIRST RELEASE DATE	REVISION DATE
				03/12/84	11/16/00
				D	041311 03